



SPEED QUEEN® MULTI-HOUSING LAUNDRY SOLUTIONS

# Stack Washer/Dryer

## Electronic Homestyle

### Built for Reliable Performance

Speed Queen's stack washer/dryer brings an innovative stacked concept that takes up half the floor space that a conventional washer and dryer does when situated side by side. The freestanding softmount design can be installed on all floor types or levels. Both washer and dryer have the same hookups and connections as a standard washer and dryer. No additional plumbing or electrical change is needed. Speed Queen's stack washer/dryer combines heavy-duty construction with reliable operation proven to stand the test of time. They're designed with less moving parts for one reason: so you'll face fewer maintenance problems and less wear and tear down the road. Front load products have met every design standard to be 100% ADA compliant.

### Washer (ADA Compliant)

- Rugged suspension system
- Industry leading 1200 RPM spin speed exerts 440 G-force extraction
- Durable stainless steel washtub
- Four-compartment soap dispenser
- Extra-wide 15.5" door opening and 180° door swing

### Dryer

- Upfront lint filter easy to clean and secured
- Industry's largest door opening 2.06 sq. ft. (1914 cm2)
- Quiet, efficient blower system

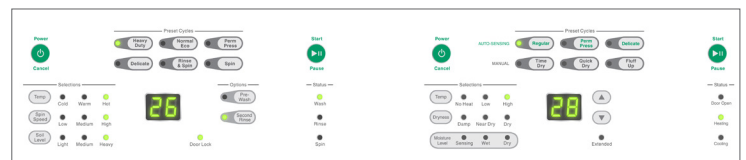

Washer Control

Dryer Control

### Electronic Homestyle Control

Electronic Homestyle control is designed for durability and easy operation with attractive selection buttons and cycle status indicator lights.

# Stack Washer/Dryer

## Electronic Homestyle

Specifications		
Control Option		Electronic Homestyle
Color		White
Capacity - lb (kg)	Washer	21.5 (9.5)
	Dryer	18 (8.2)
Cylinder Volume - cu. ft. (liters)	Washer	3.42 (96.8)
	Dryer	7.0 (198)
Motor Size - HP (kw)		0.9 (0.67)
Type Of Gas (Gas Models Only)		Factory equipped natural/mixed gas
Water Consumption Per Cycle g (liter)		13.68 (51.8)
IWF (Water Factor) gal/ft <sup>3</sup> (liters/liter/cycle)		4.0 (0.53)
MEF <sub>2</sub> (Modified Energy Factor) ft <sup>3</sup> /kWh/cycle (Liters/kWh/cycle)		2.20 (62.3)
Available Water Temperatures		Hot, Warm, Cold
Available Cycles	Washer	Heavy Duty, Normal Eco, Perm Press, Delicate, Rinse and Spin
	Dryer	Regular, Perm Press, Delicate, Time Dry, Quick Dry, Fluff Up
Air Outlet Diameter - mm (in)		4 (102)
Exhaust Airflow - cfm (liters/sec)		220 (105)
Electrical Requirements	*Electric	120/240/60/1-30 amp 120/208/240/60/1-30 amp
	Gas	120/60/1-15 amp
Heating Element	Electric	5350W, 240V 4750W, 208V
	Gas	25,000 Btu
Net Weight - lb (kg)		350 (158.8)
Shipping Weight - lb (kg)		380 (172.4)
Shipping Dimensions Approx. - in (mm)	Width	34 (864)
	Depth	30 (762)
	Height	80 (2032)
Agency Approvals	Electric	cULus
	Gas	cCSAus

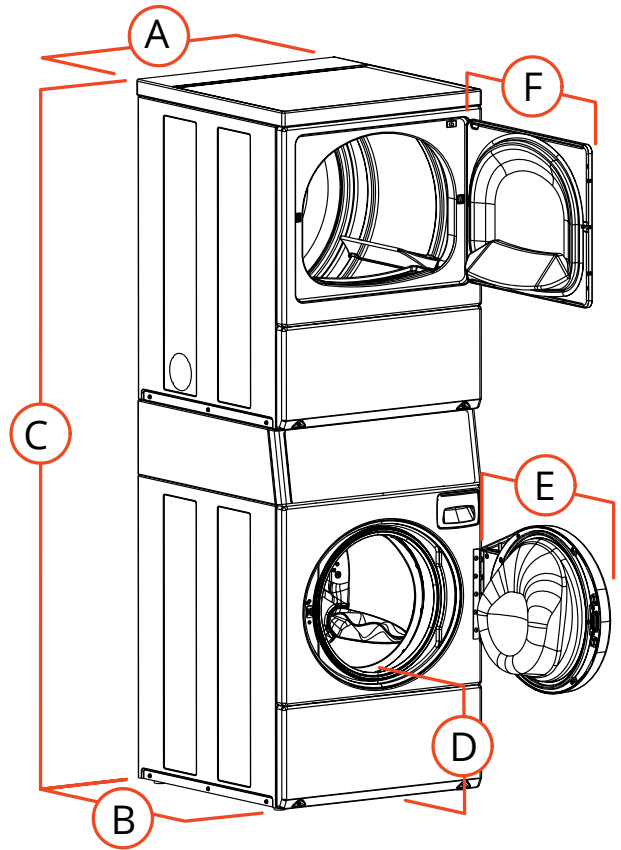

A. Overall Width - in (mm)	26.875 (683)
B. Overall Depth - in (mm)	27.73 (704)
C. Overall Height - in (mm)	78.17 (1986)
D. Floor To Door Opening -in (mm)	14.5 (368)**
E. Door Swing - in (mm)	24 (610)

\*\* For ADA compliance turn legs out from base 0.5 inches

Models	Voltage/Freq/PH	
LTEE5ASP175TW01	208-240/60/1	Electric
LTGE5ASP115TW01	120/60/1	Gas

NOTE: Stack washer/dryer requires two power cords. One for washer, one for dryer.

\* Electric dryers come equipped for 240/60/1 operation. They can be field converted to operate on 208/60/1 with optional 61928 conversion kit.

Gas dryers can be field converted for operation on LP gas with optional 458P3 conversion kit.

For the most accurate information, the installation guide should be used for all design and construction purposes. Due to continuous product improvements, design and specifications subject to change without notice. The quality management systems at Alliance Laundry Systems are registered to ISO 9001.

**Commercial product is not authorized for sale to Residential end consumers.**

©2021 Alliance Laundry Systems LLC

Speed Queen by Alliance Laundry Systems

AM21-0097

speedqueencommercial.com